

BALL VALVE

AL 24-PZ / AL 25-PZ

Description

AL 24-PZ / AL 25-PZ is a two-piece flanged ball valve with full bore with mounting plate according to ISO 5211. Manual with lockable hand lever or gear box with handwheel. Free floating ball DN 15-200 and guided ball DN 250-300. The valve is Fire Safe and have supported stem and self-adjusting packing.

Applications: Shut-off valve for demanding applications, with neutral to aggressive liquids and gases.

Type

AL 24-PZ-24-TTTG*	Carbon steel	Face-to-face EN 558 F1
AL 24-PZ-26-TTTG*	Stainless steel	
AL 25-PZ-04-TTTG*	Carbon steel	Face-to-face EN 558 F4 (F5 > DN 100)
AL 25-PZ-06-TTTG*	Stainless steel	
AL 25-PZ-09-TTTG*	Carbon steel	Face-to-face EN 558 F4 (F5 > DN 100)

*TTTG refers to seat, stem seal, primary and secondary body seal

Marking: The valve is marked PZ

Dimension: AL 24-PZ DN 15-100
AL 25-PZ DN 15-300

Connection: Flange

Pressure: PN 16/40 DN 15-50
class PN 16 DN 65-300
PN 40 DN 65-300

Pressure: 16-40 bar (see pressure/temp. diagramme)

Temperature: Stainless steel -50° - +210°C
Carbon steel 1.0619: -10° - +210°C
Type 09 carbon steel 1.6220: -46° - +240°C
(see pressure/temp. diagramme)

Pressure / Temperature - PN 16

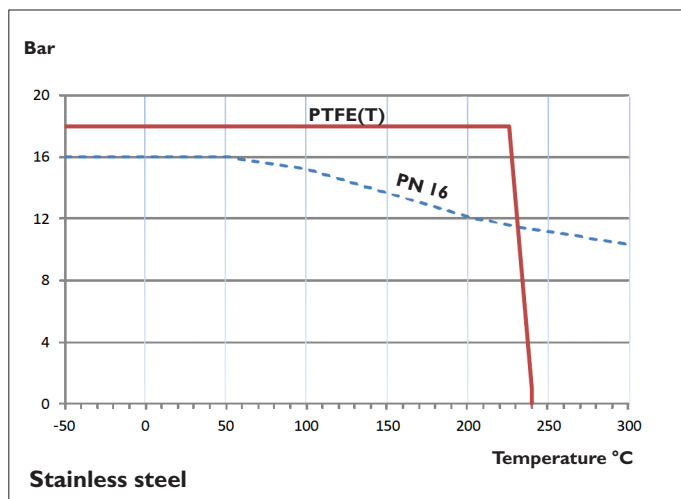

Approvals

- CE/PED 2014/68/EU
- ATEX 2014/34/EU
- TA-Luft
- FireSafe certificate
- EN161/EN264
- SIL3

Optional

- ANSI
- Stem extension
- Gear box over DN 250
- Electric actuator
- Pneumatic actuator

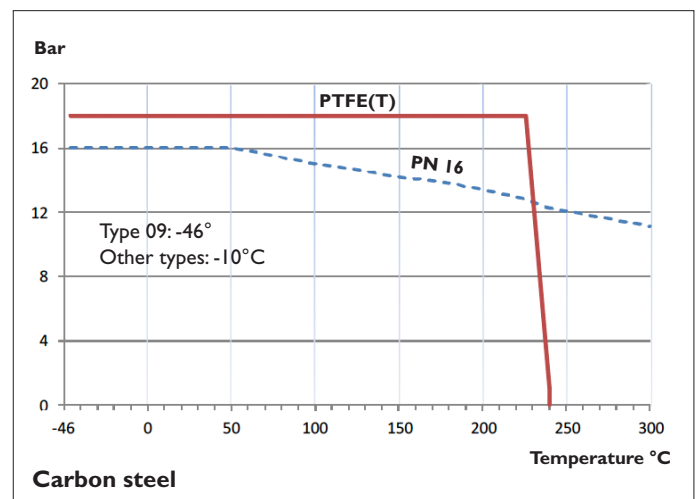

BALL VALVE

AL 24-PZ / AL 25-PZ

Pressure / Temperature - PN 40

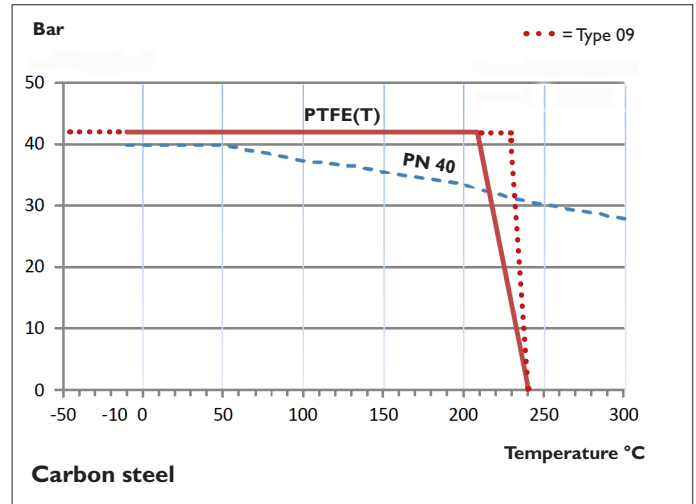
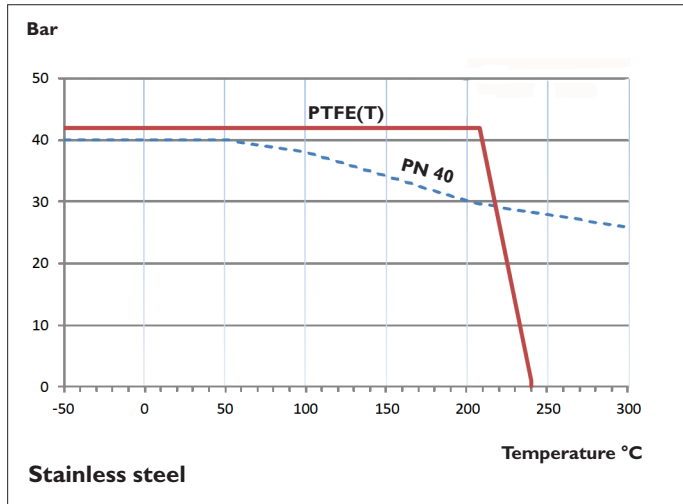

Material specification

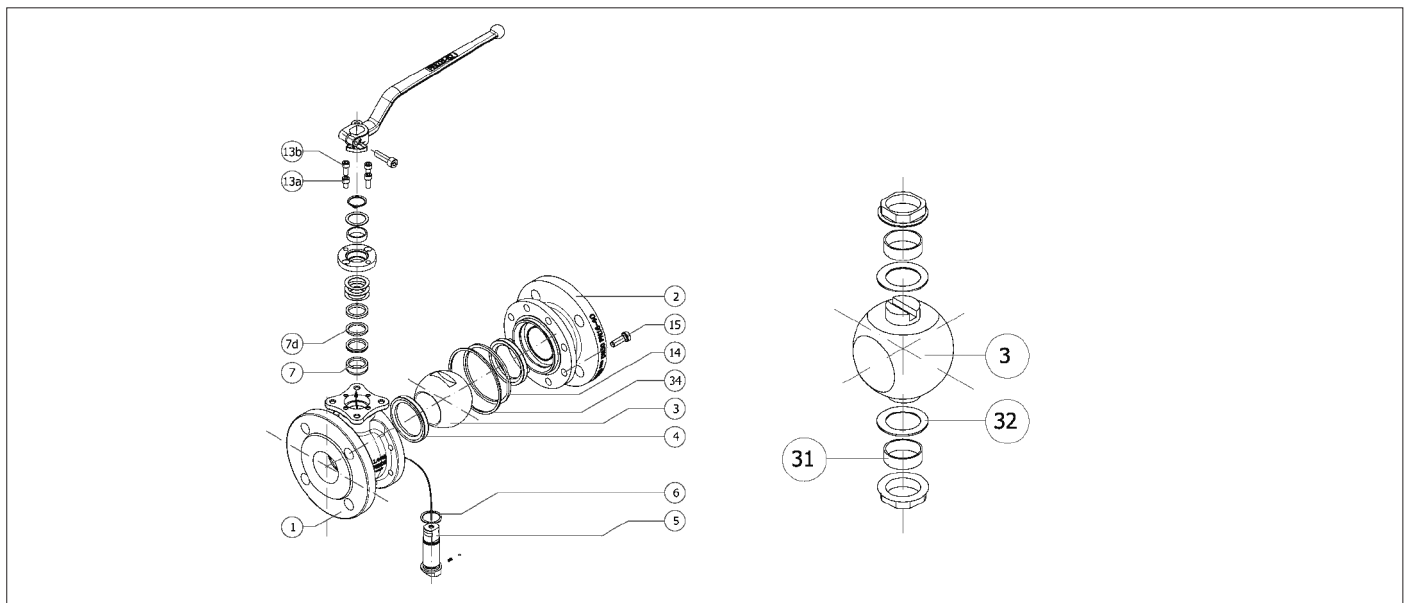

Pos	No	Part	Carbon steel	Stainless steel
1	1	Body	Carbon steel I.0619 (I.6220 type PZ-09-TTTG)	Stainless steel I.4408
2	1	Body adapter	Carbon steel I.0619 (I.6220 type PZ-09-TTTG)	Stainless steel I.4408
3	1	Ball	Stainless steel I.4408	Stainless steel I.4408
4	2	Seat	PTFE	PTFE
5	1	Stem	Stainless steel I.4401	Stainless steel I.4401
6	1	Stem seal	PTFE + Glass fiber	PTFE + Glass fiber
7	1	Packing 1	PTFE	PTFE
7d	1	Packing 2	Graphite	Graphite
13a	4	Bolt	A4-70	A4-70
13b	2	Bolt	A4-70	A4-70
14	1	Body seal 1	PTFE	PTFE
15	-	Body bolt	B7M	B8M
31	2	Bearing	PTFE	PTFE
32	2	Bearing disc	PTFE + Glass fiber	PTFE + Glass fiber
34	1	Body seal 2	Graphite	Graphite

BALL VALVE

AL 24-PZ / AL 25-PZ

Dimensions

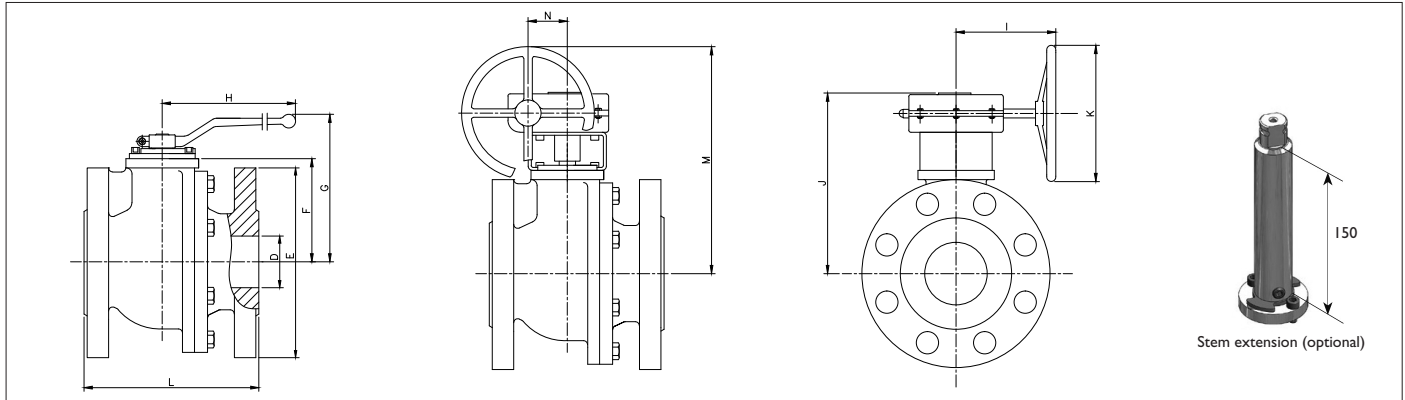

DN	D	L			E* PN 16	E PN 40	F	G	H	I	J	K	M	N	Weight kg Including gear box in brackets			Kv
		F1 AL 24-PZ	F4 AL 25-PZ	F5 AL 25-PZ											F1 ¹⁾	F4 ²⁾	F5 ³⁾	
15	15	130	115	-	95	95	52	100	185	-	-	-	-	-	3	3	-	13
20	20	150	120	-	105	105	54	102	185	-	-	-	-	-	4	3	-	34
25	25	160	125	-	115	115	60	110	185	-	-	-	-	-	5	4	-	60
32	32	180	130	-	140	140	65	115	185	-	-	-	-	-	7	6	-	94
40	40	200	140	-	150	150	75	129	293	170	203	300	310	60	9 (13)	8 (12)	-	213
50	50	230	150	-	165	165	83	137	293	170	210	300	318	60	12 (16)	11 (15)	-	366
65	65	290	170	-	185	185	96	150	293	170	223	300	330	60	19 (23)	15 (18)	-	595
80	80	310	180	-	200	200	114	187	450	170	261	300	379	60	26 (30)	20 (23)	-	935
100	100	350	190	-	220	235	128	201	450	170	286	300	393	60	33 (37)	29 (32)	-	1700
125	125	-	-	325	250	270	158	247	740	210	328	400	472	70	-	-	58 (64)	3145
150	150	-	-	350	285	300	175	264	740	210	345	400	482	70	-	-	75 (82)	4590
200	200	-	-	400	340	375	245	334	750	272	435	500	635	100	-	-	137 (165)	8330
250	250	-	-	450	405	450	285	-	-	272	475	500	675	100	-	-	220 (248)	13940
300	300	-	-	500	460	515	336	-	-	272	526	600	808	100	-	-	290 (318)	20230

¹⁾ EN 558 series I ²⁾ EN 558 series I4 or 27 ³⁾ EN 558 series I5 or 27

* Please note that the manufacturer changes to 8 bolt holes for PN 16, acc. to new EN standard, please contact us for current status.

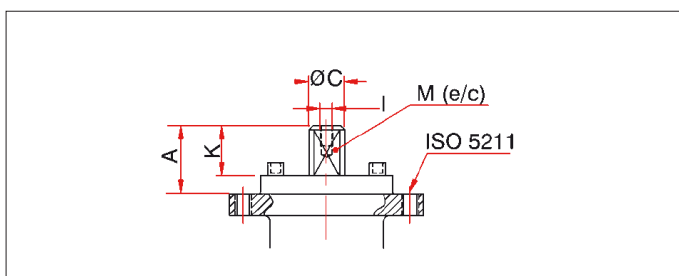

Mounting plate according to ISO 5211

DN	15	20	25	32	40	50	65	80	100	125	150	200	250	300
ISO 5211	F05	F05	F05	F05	F07	F07	F07	F10	F10	F12	F12	F14	F14	F14
M	11	11	14	14	17	17	17	22	22	27	27	36	36	36
C	14	14	18	18	22	22	22	28	28	36	36	48	48	48
A	13,5	13,5	19,5	19,5	30	30	30	40	40	50	50	63	63	63
K	11	11	17	17	20	20	20	22	22	35	35	40	40	40
I	M4	M4	M4	M4	M6	M6	M6	M8	M8	M8	M8	M8	M8	M8

Installation

The valve can be installed in horizontal and vertical lines. The valve is maintenance free but should be operated at regular intervals depending on the installation.

Actuator sizing

Media clean water 20°C and 16 bar, safety factor 30%. Supply air 6 bar.

Valve DN	Torque Nm	AL 77		AL 78	AL 79	
		DA	SR	Electr	DA	SR
15	11	210-DA	210-SR	003	051U-DA	101U-SR
20	13	210-DA	220-SR	003	051U-DA	101U-SR
25	19	210-DA	220-SR	003	101U-DA	201U-SR
32	30	210-DA	230-SR	005	101U-DA	201U-SR
40	41	220-DA	230-SR	005	201U-DA	251U-SR
50	60	220-DA	240-SR	009	201U-DA	301U-SR
65	72	220-DA	240-SR	009	201U-DA	301U-SR
80	111	230-DA	250-SR	015	301U-DA	351U-SR
100	143	230-DA	250-SR	015	301U-DA	401U-SR
125	312	250-DA	260-SR	038	451U-DA	501U-SR
150	494	260-DA	270-SR	050	451U-DA	601U-SR
200	702	260-DA	280-SR	080	601U-DA	651U-SR
250	1235	270-DA	280-SR	150	601U-DA	701U-SR
300	1560	270-DA	288-SR	200	651U-DA	701U-SR