

BALL VALVE

AL 37-PV

3-way ANSI

Description

AL 37-PV is a full bore 3-way ball valve according to ANSI standard with a mounting plate according to ISO 5211. The valve is antistatic with an autoadjustable packing.

- Floating ball
- Soft seat
- ANSI class 600
- Anti blow-out proof stem.
- The ball is available in L and T versions.
- Self-cavity pressure relief.
- Allows in-line maintenance
- Fire Safe design
- Buttwelding ends B16.25
- Threaded ends NPT (carbon steel)
- Materials according to NACE MR0175
- Design B16.34
- Testing API 598, BS 6755-1

Versions: AL 37-PV-89-SGS-V - Carbon steel
AL 37-PV-86-SGS-V - Stainless steel

Approvals

- ATEX 2014/34/EU
- CE/PED 2014/68/EU
- SIL 3 capable

Configurations

Standard = LI and TI, other configurations on request.

3-way

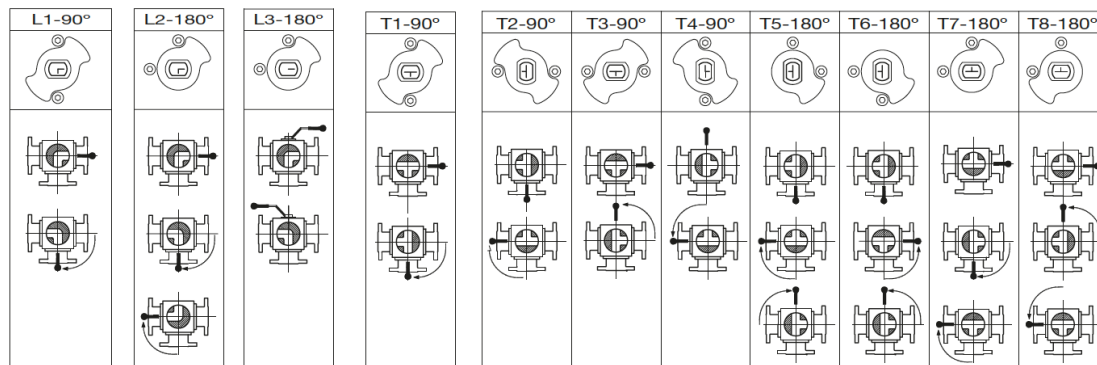

4-way (optional)

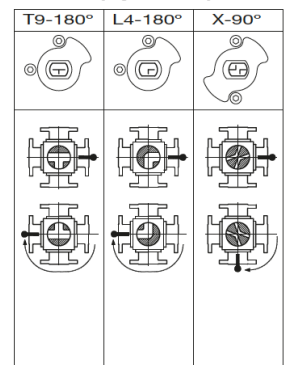

Pressure / Temperature

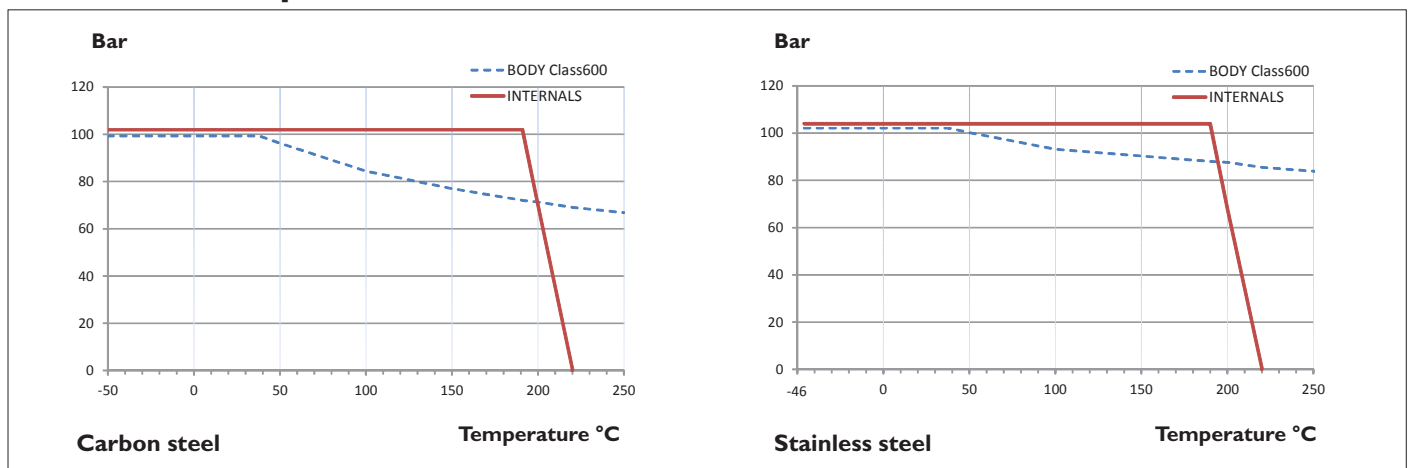

BALL VALVE

AL 37-PV

3-way ANSI

Material specification

No	Description	Stainless steel	Carbon steel
1	Body I	A182 F316/316L	A350 LF2/A-105
2	Body 2	A182 F316/316L	A350 LF2/A-105
3	Ball	A182 F316/316L	A182 F316/316L
4	Seat	PTFE (modified)+CG	
5	Stem	S.S.AISI 316/316L	
6	Stem seal	PTFE (modified)+CG	
7	Stem packing I	Graphite	
8	Gland packing I	S.S.AISI 316	
9	Spring washer	S.S.AISI 301	
10	Stem nut	S.S.AISI 304	
13	Cover bolt	S.S. (316)	
14	Body seal I	PTFE (modified)+CG	
15	Body bolt	A193 B8M	A320 L7M
16	Handle	C.S. painting	C.S. painting
18	Thrust washer	PTFE (modified)+CG	
19	Spring	S.S.AISI 316	
20	Antistatic ball	S.S.AISI 316	
35	O ring stem	FKM	
43	Seat seal	FKM	
44a	Ring seat I	S.S.AISI 316	
94	Stop washer	S.S.AISI 301	

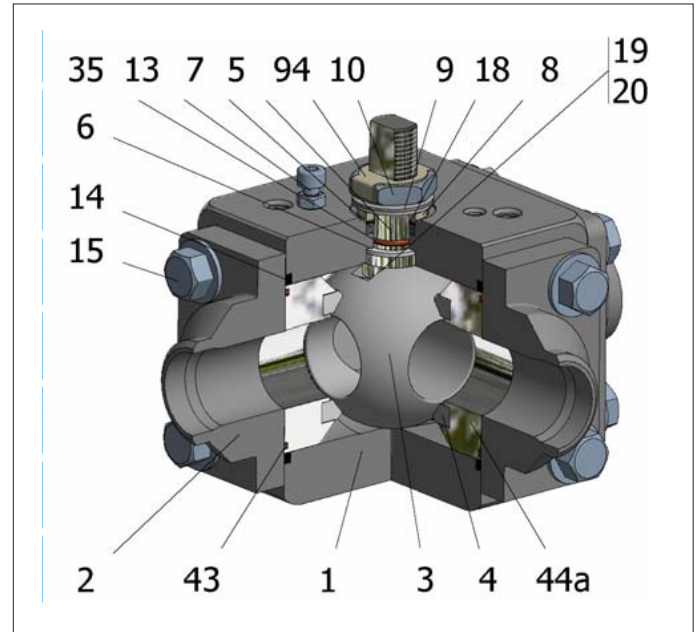

Dimensions

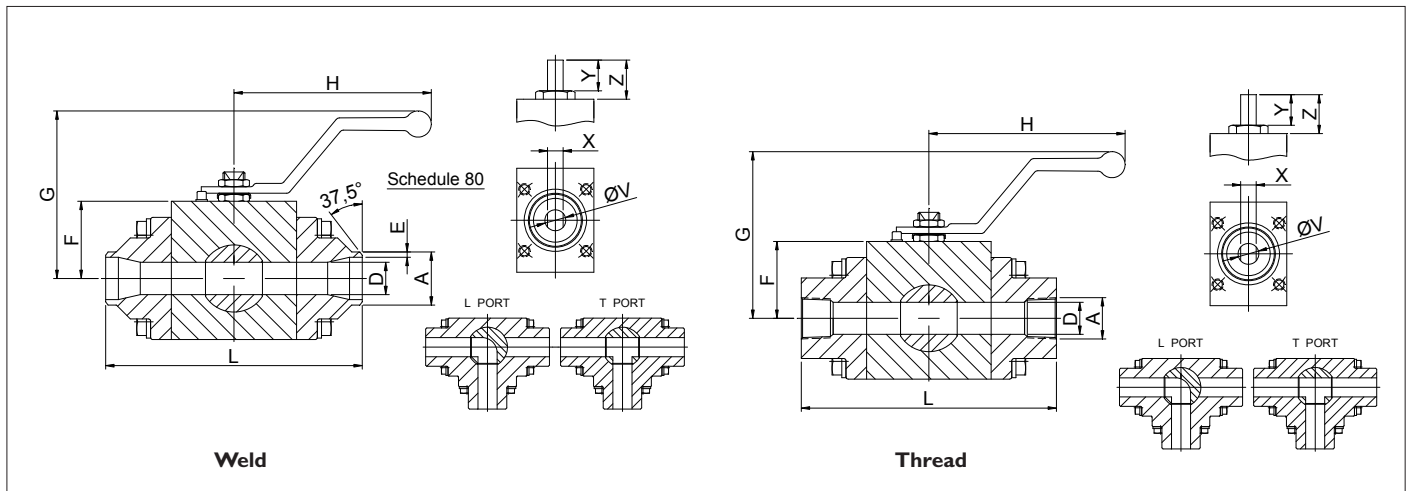

DN	D	L	E	AI Weld	A Thread	F	H	G	V	X	Y	Z	ISO 5211	Nm	Weight kg
15	14,2	119	3,73	21,3	1/2"	30,0	180	97	12	7,5	14	23,0	F04/-	16	3
20	21,0	150	3,91	26,7	3/4"	39,5	180	102	12	7,5	14	18,5	F04/F07	25	5
25	25,5	158	4,55	33,4	1"	42,5	220	114	15	9	18	28,0	F05/F07	36	7

*Torque (Nm) at room temperature and maximum pressure for the respective pressure class (without any safety factor)



Telephone +46 10 455 97 00 • sales@axel-larsson.se • www.axel-larsson.se

STOCKHOLM | GÖTEBORG | MOTALA | FALUN | UMEÅ

Head Office: Truckvägen 12, P.O. Box 805, SE-194 28 Upplands Väsby (Stockholm), Sweden.