

# MANUAL

## Ball valve AL 25-90D

### BRIEF INTRODUCTION

Split body (2-piece) valve allows easy replacement of gasket, seal, and seats without special tools. Series 90D ball valves use “floating ball” design. Induced by the line pressure the ball is free to move horizontally inside the valve body. The valve is capable of tight shutoff with flow in either direction or dead-end, regardless of the position of the valve in the line. The downstream seat, opposite the pressurized side of a closed valve, carries the load exerted by the line pressure on the ball, while the upstream seat is subject to little load or wear. For this reason, it is sometimes possible to increase seat life by turning the valve end-for-end in the pipeline.

### 1. USE

1.1 Life of valve can be maximized if the valve is used within the rated range, in accordance with pressure, temperature, and corrosion data.

### 2. MANUAL OPERATION

2.1 To open or close the valve, turn the handle  $\frac{1}{4}$  turn (90 degrees).

A. Valve in Open Position – the handle is in parallel (in-line) with the valve or pipeline.

B. Valve in Closed Position – the handle is perpendicular (crossed) with the valve or pipeline.

### 3. AUTOMATED OPERATION

3.1 Valves with actuators should be checked for valve stem alignment. Angular or linear misalignment will result in high operational torque and unnecessary wear on the stem seal.

### 4. GENERAL INFORMATION FOR ON-SITE INSTALLATION

4.1 The valve may be fitted in any position on the pipeline.

4.2 To prevent damage to the seats and ball surface, the pipeline must be flushed, free of dirt, burrs, and welding residues before installing the valve.

### 5. DISASSEMBLING & CLEANING THE VALVE

5.1 If the valve has been used in hazardous media, it must be decontaminated before disassembly.

5.2 As shipped from the factory, valves contain silicone-based lubricant. If silicone is unacceptable for your particular application, you may disassemble the valve and wash the parts in solvent.

### 6. REPLACING THE THRUST WASHER AND PACKING

6.1 Before replacing the thrust washer and the packing, the pipeline must be de-pressurized.

**Note:** Stem seal leakage may be corrected without replacing the seal and/or packing. Tighten the packing nut to flatten the belleville washers. If leakage continues or valve’s operating torque becomes excessive, the seals are worn and must be replaced.

A. Remove flange bolts and nuts and lift the valve from the line. Care should be taken to avoid scratching or damaging serrated gasket. The valves are heavy, and they should be adequately supported before removing it from the line.

B. Loosen the stem nut and remove handle and stop plate. Next, remove lock saddle, packing nuts, belleville washers and gland.

C. Remove body bolt nuts, using proper wrench. Lift off body end.

One seat should come out with the body end.

D. Remove body seal.

E. To take out the ball, rotate stem so ball is in fully closed position. Lift ball from the body, using a strap and lift device, if necessary. Extreme caution should be taken to avoid damage to the ball.

F. Take out the other seat.

G. Stem must be removed from inside the body. A tap to the top of the stem should loosen it. The thrust washer should come out with the stem. Then, remove the stem packing.

### 7. VISUAL INSPECTION

7.1 Clean and inspect metal parts. It is not necessary to replace neither ball nor stem unless the surface has signs of abrasion or corrosion. We strongly recommend replacement of all soft parts whenever the valve is disassembled for reconditioning. We provide replacement kits that contain all the replaceable parts.

Note: The valve may be assembled and operated dry with any lubricant. However, a light lubrication will aid in assembly and reduce initial operating torque. Lubricant used must be acceptable with the intended line fluid.

### 8. ASSEMBLY

Install one seat in the body cavity with the spherical curvature facing the ball.

8.1 Install the thrust washer on stem and slide the stem up through the body. Install packing, gland, belleville washers, locking saddle.

Screw the packing nut into the stem. Lock the saddle in place.

8.3 Install stop plate, handle and washer. Screw the stem nut into the stem until the handle is secure.

8.4 Turn handle to the closed position. Line up the ball slot with the stem end and slide the ball into position. Turn the handle to the open position to hold the ball in place.

8.5 Install the remaining seat into body side.

8.6 Put body seal gasket into body and line up end flange. Because the body flange bolt pattern is different from the line flange bolt pattern, it is possible to assemble the valve such that the line flanges bolt pattern don’t line up. Be certain to align end flanges bolt holes to straddle valve center lines. Be careful not to damage body seal when putting cap end into body.

8.8 Install cap end nuts and tighten in the “star” pattern to the proper torque. Extreme care must be exercised during adjustment of cap end nuts to make sure that complete engagement of the studs with body flange is maintained. There should be at least one stud thread exposed on each side.

8.9 Cycle the valve slowly, with a gentle back and forth motion, to build gradually to the full quarter turn. By cycling slowly, the seat lips will assume a permanent seal shape against the ball. A fast turning motion, at this point, may cut the seats before they have a chance to form the proper seal.

8.10 Test valve, if possible, prior to placing valve back into line position. If not properly secured, the valve can separate from the pressure source, resulting in possible injury. Always join the valve to companion flanges of same pressure rating as valve and secure with a full set of flange bolts.

# MANUAL

## Ball valve AL 25-90D

### TEST AS FOLLOWS

A. Secure valve to a test fixture by means of a mating flange with full bolting and a suitable gasket. Orient valve so seat to be tested is facing up.

B. Introduce 50 to 100 psig air. Partially cycle the valve, under pressure, then slowly close to make sure the cavity is pressurized (use hearing protection). Pour water into the upper port to cover the ball and visually check for bubbles. If bubbles appear, pour the water out, cycle the valve several times and recheck. To check for leakage in the other port, reverse the valve and introduce air pressure to the port just checked.

C. Check stem seal at this time by coating the stem top area with a water/soap solution. If leakage occurs, tighten stem seal just until leakage stops.

Pos	Qty	Part	Material
1	1	Body	CF8M / WCB
2	2	End cap	CF8M / WCB
3	1	Ball	SUS 316
4	1	Stem	SUS 316
5	1	Stem nut	SUS 304
6	2	Belleville washer	SUS 301
7	1	Handle	SUS 304
8	2	Seat	RTFE
9	1	Gland bush	SUS 304
10	*	V-ring packing	PTFE
11	1	Stem seal	RPTFE
12	1	Lock saddle	SUS 304
13	2	Joint gasket	PTFE
14	**	Bolt (stud&nut)	SUS 304
15	1	Stop pin	SUS 304
16	1	Handle sleeve	Vinyl
17	1	Gland packing	25% glass fiber filled + PTFE
18	1	Stem washer	SUS 304
19	1	Pin nut	SUS 304
20	1	Locking device	SUS 304
21	1	Antistatic device	SUS 304
22	1	Handle nut	SUS 304
23	1	O-ring	Viton

\* 1/2" - 1": 1 set of v-ring packing consists of 2 pcs of v-ring  
1 1/2" - 6": 1 set of v-ring packing consists of 3 pcs of v-ring

\*\* 1/2" - 2": 4 pcs of bolt. 2 1/2" - 4": 8 pcs.

6": 10 pcs of stud and nut (150 lbs)

1/2" - 2": 4 pcs of bolt. 2 1/2": 6 pcs. 3" - 5": 8 pcs.

6": 10 pcs of stud and nut (PN I6)

Valve size	Breakaway Torque 30% safety factor	
	Lbs	Nm
1/2"	100	11
3/4"	140	15
1"	150	17
1 1/4"	160	18
1 1/2"	360	40
2"	400	45
2 1/2"	480	54
3"	700	79
4"	1200	135
5"	1500	169
6"	1700	191

Valve size	Torque of body bolt	
	Lbs	Nm
1/2"	180 - 200	20 - 23
3/4"	200 - 225	23 - 25
1"	265 - 290	30 - 33
1 1/4"	290 - 310	33 - 35
1 1/2"	355 - 400	40 - 45
2"	355 - 400	40 - 45
2 1/2"	355 - 400	40 - 45
3"	485 - 530	55 - 60
4"	485 - 530	55 - 60

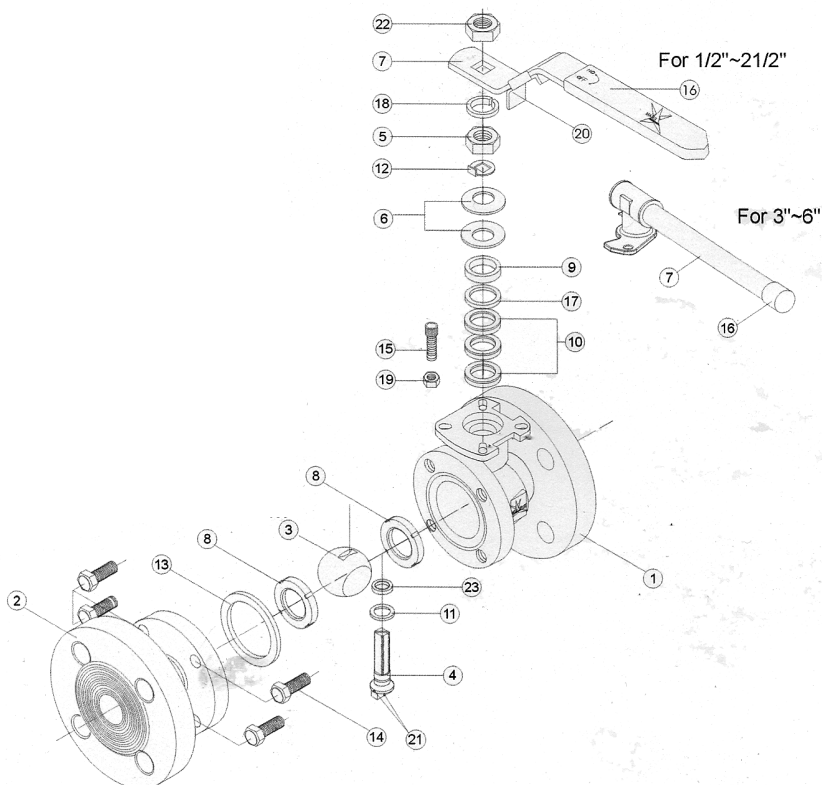

# AXEL LARSSON

Telephone +46 10 455 97 00 • sales@axel-larsson.se • www.axel-larsson.se

STOCKHOLM | GÖTEBORG | MOTALA | KARLSTAD | FALUN | SKELLEFTÅ

Head Office: Truckvägen 12, P.O. Box 805, SE-194 28 Upplands Väsby (Stockholm), Sweden.